

Authority: **International Displacement Division Class Association (ID2CA),**

International Windsurfing Association

Mengham Cottage Mengham Lane
Hayling Island
Hampshire
PO119JX
United Kingdom

1. GENERAL

- 1.1 The International Displacement Division of Sailboards (Division II) is a single handed development class.
- 1.2 The International authority for the International Displacement Division of Sailboard is the ID2CA.
- 1.3 Interpretations of these rules shall be made by the ID2CA which may consult the International Windsurfing Association (IWA) and / or World Sailing.
- 1.4 No liability or legal responsibility in respect of these rules can be accepted by the ID2CA or its delegated representatives.

2. ADMINISTRATION

2.1 Language

- 2.1.1 The official language of the division is English and in the event of a dispute over interpretation the English text shall prevail.
- 2.1.2 The word “shall” is mandatory and the word “may” is permissive.

2.2 National Authority

In countries where National Authority (NA) does not wish to undertake the administration of the Displacement Division of Sailboards, its functions as stated in these rules shall be carried out by the National Class Association (NCA) which is recognized by the IWA or by ID2CA if there is no NCA

2.3 Eligibility to Race

- 2.3.1 No sailboard shall race in the international Displacement Division unless it complies with the current rules.
- 2.3.2 It is the owner’s responsibility to ensure that his sailboard complies with the ID2CA Class rules at all times and that alteration or replacements to the sailboard do not contravene the rules.
- 2.3.3 (a) No sailboard shall sail in division II in official events unless it carries numbered ID2CA stickers on the Board and on each sail. Those stickers indicate that the International Class Fees for the board and the sails have been paid..

(b) The sticker on the board shall be glued on the board, within a radius of 500mm from its bow. The sticker shall be glued on the sail within a radius of 600mm from the tack point of the sail.



2.4 Measurement

2.4.1 (a) The primary method of determining compliance with measurement rules shall be by measuring boards and equipment of high finishing competitors after race completion. This procedure shall be followed in major regattas or when notice of race so prescribe.

(b) Race organizers shall provide measurement facilities prior to the commencement of racing for those requesting it in reasonable time and shall maintain measurement facilities opened and operational throughout the entire Event.

2.4.2 Only a measurer officially recognized by the National Authority or the ID2CA of the country in which the measurement is undertaken shall measure a sailboard, its mast, sail and equipment. If no such bodies exist the ID2CA or IWA may appoint a Measurer.

2.4.3 The measurer shall report to the ID2CA and the NA as well as the Race Committee anything which he may consider to depart from the intended nature of the international Displacement Division, or to be against the interests of the sport and to this event notwithstanding anything in these rules, the ID2CA or NA or Race Committee may refuse to let a sailboard race

2.4.4 All sailboards shall be liable to measurement checks by the recognized Measurer at the discretion of the ID2CA, the NA or the race committee at any time.

2.5 ID2CA Measurement instructions

2.5.1 Except where other methods of measurement are specifically indicated, all measurements shall be carried out with the current ID2CA Measurement Instructions (See ID2CA current measurement instructions in Appendix A).

2.5.2 All measurements shall be in metric units

2.6 Identification Marks

- 2.6.1 The NA shall issue numbers which shall be consecutive and the numbers shall be preceded by the National Letter (s). It shall be sailor's responsibility to mark his /her sails with those sail numbers according to ID2CA Class rules
- 2.6.2 The sail shall carry the National Letter (s), National Number and the sailboard insignia, if it has one, in accordance with the ID2CA Racing Rules. From storm sails, numbers may be lower down the sail, but never below the wishbone. The minimum size of sail letters and numbers shall be:

Height	225mm
Width	145mm (Excluding number one and letter I)
Thickness	30mm
Spacing	45mm

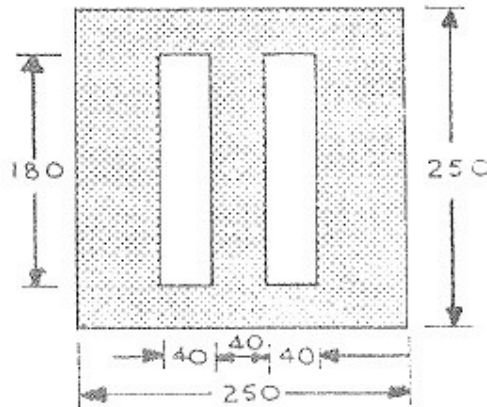

- 2.6.3 The sail shall carry the Division II insignia above the boom height in proximity of the clew. The insignia shall be as indicated in the diagram.
- 2.6.4 The Division insignia may be carried on the starboard side of the sail only.
- 2.6.5 All insignia, letters and numbers shall be of a durable material, of a color contrasting with the sail, and shall be securely attached.
- 2.6.6 If the racing is divided into groups, the heavy weight group shall carry a circular disc on both sides of the sail in the proximity of the head. The minimum diameter of the disc shall be 150mm. A women's group should carry an equilateral triangle, pointing downwards, on both sides of the sail in the proximity of the head. The minimum length of side shall be 150mm.

3 CONSTRUCTION AND MEASUREMENT RULES

3.1 Spare number

3.2 Board

The use of ID2CA approved measurement tools as well as methods for measuring boards are described in Appendix A.

All board measurements are to be taken with the internal board pressure normalized to the external pressure, i.e. with the bungs removed.

3.2.1 The maximum length shall not exceed 3900mm. If a drain, bung or the towing eye, required by rule 3.2.10 is a separate fitting attached to the board the overall length, including such fitting, shall not exceed 3920mm

3.2.2 In these rules “the fair deck line” refers to the fore and aft line of the deck at its highest point in transverse section, disregarding any local variation. The fair underside need not be on the centerline of the board.

3.2.3 In these rules “the fair underside” refers to the fore and aft line of the hull at its lowest point in transverse section, disregarding any local variations. The fair underside needs not to be on the centerline.

3.2.4 The minimum width shall be 630 mm at the widest point of the board, disregarding any local variations, at half height between the fair deck line and the fair underside, unless the widest point of the board is below the half height then the width is measured at the widest point.

3.2.5 A minimum width of 590mm shall be measured as in 3.2.4 over a length of 1300mm of the board parallel to the centerline.

3.2.6 The maximum depth of the board measured from the deck line to the fair underside shall not exceed 220mm anywhere on its length, disregarding any local variation or fittings. The measurer may require the removal of such fittings, if in his opinion, it is necessary, for a correct measurement. Mast Tracks, mast leashes, mast steps and other attachments which affect a measurement as described in 3.2.4, 3.2.5 and 3.2.6 shall be removable.

3.2.7 There shall be no visible air gap dividing the board longitudinally throughout its length when afloat in an upright sailing position fully equipped but without crew.

3.2.8 (a) The board shall incorporate closed cell foam buoyancy, or expanded polystyrene, as follows;

- (1) When the owner can show the board structure contains not less than 150 liters or
- (2) When the owner can show the board structure contains not less than 50 liters, and the board contains two blocks each not less than;
 - a. 200mm x 150mm x 1000mm or
 - b. 150mm x 150mm x 1500mm

Fixed between the 590mm beam measurement points in such a manner as to allow access and facility to checking

This shall be deemed sufficient, otherwise;

- (3) The hull shall contain not less than 100 liters in not more than two solid rectangular blocks, fixed in such a manner as to allow access and facility for checking

(b)The measurer may require board owners to insert up to two inspection bungs in the hull in such a way that the internal foam may be checked.

3.2.9 The weight of the board:

- (A and B from 91) with skeg (s) but without centerboard or other equipment shall be not less than 18kg when in a clean and dry state. Corrector weights up to a maximum of 1.5kg, if required, shall be fixed in one place inside the hull in a manner that allows the measurer access and facility to check and to affix seals. Corrector weights may be fixed in the dagger board case or in one of the mast steps, and shall be fixed in such a way that they can sealed for the duration of a regatta.
- (C from 2015) with skeg(s) and footstraps but without centerboard or other equipment or appendices, shall be not less than 16.5 kg when in a dry and clean state and inclusive corrector weights

3.2.10 a towing eye and a mast leash attachment shall be fitted to the board. The towing eye shall be capable of supporting a minimum of 150kg suspended from it. The mast leash is governed by 3.7.3. The towing eye shall be capable of receiving a 10 mm towline and positioned within 200mm of the bow.

3.2.11 Any board may be disallowed on grounds of safety if the hull has any sharp upwards projecting edges of radius less than 15mm.

3.2.12 Foot straps are allowed. Any part of the foot strap and foot strap fittings above the fair deck line shall be defined as “other equipment” in the sense of rule 3.2.9 and shall be removable.

3.3 Centerboard

3.3.1 The depth of the centerboard shall not exceed 700mm measured normal to the fair underside of the board

3.3.2 The centerboard shall be capable of insertion into the board from its upper side and shall have stops to prevent it exceeding the depth in rule 3.3.1

3.4 Skeg (s)

3.4.1 The depth of the skeg (s) shall not exceed 300 mm for Type A&B, 400mm for Type C categories, measured normal to the fair underside of the board.

3.4.2 The skeg (s) shall be not more than 700mm from the stern. If two skegs are fitted they shall be an equal distance from the stern.

3.4.3 Remote methods of skeg adjustment by control lines or any other means are prohibited. The skeg(s) shall not project above the deck.

3.5 Mast

3.5.1 The length of the mast for "Type A" rigs shall not exceed 4800mm measured from the deck at the mast foot. For "Type B" rigs the length of the mast shall not exceed 5300mm. For "Type C" rigs the length of the mast shall not exceed 6000mm. The measurement shall include any local raising of the deck which has the effect of increasing mast height.

3.5.2 At any cross section normal to the mast's axis, the mast shall be circular and of uniform wall thickness. The bending curve shall be equal in every direction. A tapered mast is allowed. Bent masts are prohibited.

The bend curve shall be checked as follows; support the mast 50mm from each end, suspend a weight of approx. 20kg 1.7 meters from the base and measure the deflection from the horizontal. Rotate the mast trough 90°, 180° and 270° on the longitudinal axis and repeat the test. There shall be no more of 10% difference in any of the deflections and the deflection should not exceed 50mm when not under load.

3.5.3 The construction of the joint and downhaul fitting between the mast and board is optional but it shall be possible to incline the mast to an angle of at least 90° to the vertical in every direction unless the sheer of the deck prevent this.

3.5.4 The mast shall be capable of quick release from the board, without the use of tools.

3.6 Boom

3.6.1 The size of the boom is optional for "Type A" and "Type B"

3.6.2 The size of the boom shall not exceed 3000mm for "Type C"

3.6.3 Material is optional.

3.7 Fitting and Control Lines

3.7.1 There shall be no lines and fittings acting to control the mast bend other than the outhaul, kicker (boom vang) or topping lift.

3.7.2 Harness attachments may be fitted to the boom and may be adjustable.

3.7.3 The mast shall have a safety line attached to the board to prevent the mast parting from the board if the mast step releases. The safety attachment shall have a breaking strain of not less than 100kg in any direction.

SAILS

Three (3) types of sails are specified (A, B and C)

3.8 Type A – (short battens)

3.8.1 The sail shall be made in accordance with the requirements of the ID2CA Sail measurement Instructions except that non-woven and multi-ply sails are permitted.

3.8.2 These rules are for a triangular sail, in which the mast pocket forms part of the sail. The mast pocket shall not exceed 150mm in width as shown in the diagram and shall extend downwards to the tack measurement point or beyond.

3.8.3 The tack of the sail shall be at the point on the forward edge of the mast pocket which is opposite to the point at which the foot or its extension intersects the rear edge of the mast pocket, and where the line between these two points is at right angles to the forward edge of the mast pocket. See diagram.

3.8.4 The clew shall be at a point at which the foot or its extension intersects the leech or its extension.

3.8.5 The head shall be at a point on a forward edge of the mast pocket where the sail is 150mm wide, measured perpendicular to the forward edge of the mast pocket. The sail shall be made so that the head be found in this way.

3.8.6 The sail dimension shall be a maximum of:

Luff	AE	4400mm
Leech	AG	4300mm
Head to midfoot	AF	4300mm
$\frac{3}{4}$ height width	BK	940mm
$\frac{1}{2}$ height width	CJ	1680mm
$\frac{1}{4}$ height width	DH	2270mm
Foot	EG	2580mm

As shown on the sail diagram

3.8.7 The half points on the luff leech and foot shall be found by folding the head to the tack, head to the clew and clew to the tack respectively. The quarter and three-quarter points shall be found by folding the head, attack and clew to the half-point on the luff and leech.

3.8.8 The total area of the transparent part of the sail window (S) shall be a minimum of 0.4 m²

3.8.9 There shall be a maximum of three batten pockets which shall be on the leech. Battens shall be removed for measurement.

(a) In the case of three pockets they shall be positioned so that their centerlines are not more than 100mm from the leech measurement points.

(b) In the case of two the upper pocket shall not be higher than the three-quarter height, and the lower pocket shall not be higher than half height.

(c) In the case of one pocket it shall not be higher than the three-quarter height.

3.8.10 The length of the batten pockets shall not exceed:

<u>Three pockets</u>	<u>Two pockets</u>	<u>One pocket</u>
Top 375mm	Upper 375mm	375mm
Middle 725mm	Lower 725mm	
Lower 525mm		

And their width shall not exceed 40mm.

3.8.11 Lines in the leech and/or foot of the sail are prohibited, except that a non-adjustable leech line may be used to reinforce the leech of a sail without batten pockets.

3.8.12 Only one attachment position may be fitted at the tack and one position may be fitted at the clew. Reefing systems may be fitted.

3.8.13 Headboards are prohibited

3.8.14 Sails shall carry the identification marks required by rule 2.6. Any sail maker's mark shall be within 385mm of the tack, which for the purpose of this rule shall be taken as the intersection of the aft side of the mast pocket and the foot of the sail.

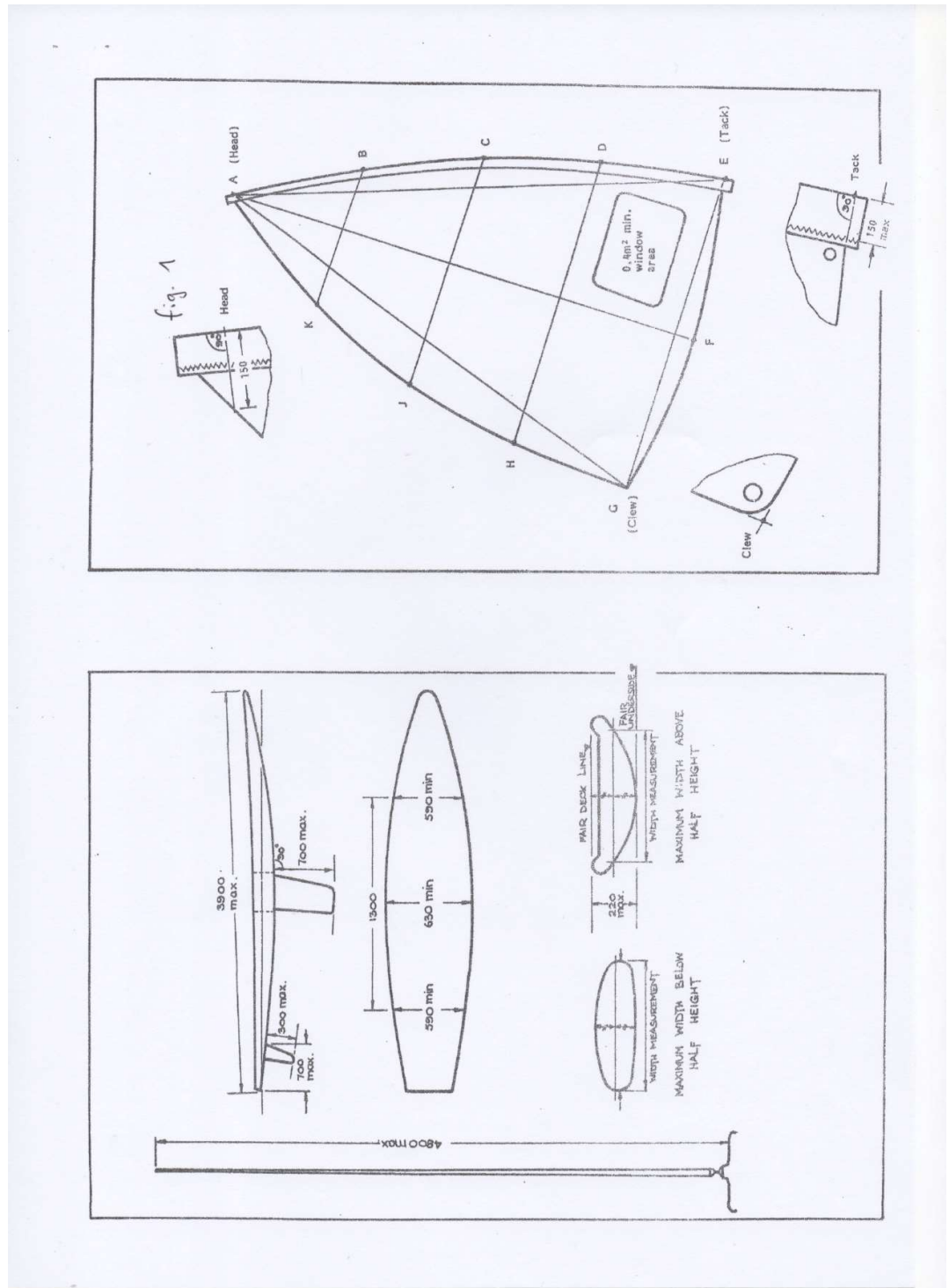

3.9 Type "B" Sail – Fully battened (optional design)

3.9.1 The sail shall be made in accordance with the requirements of the WS sail Measurement Instructions except that non-woven and multi-ply sails are permitted

3.9.2 The number and length of battens is optional

3.9.3 The mast pocket shall extend downwards to within 300mm of the tack measurement point or beyond. The width of mast pocket is optional.

3.9.4 The tack of the sail, point Y, shall be determined in one of two ways depending on the sail configuration:

(a) If the mast pocket extends downwards beyond the intersection or fair extension of foot of sail. The tack of the sail, point Y shall be as in rule 3.8.3

(b) If the mast pocket is not as specified in (a). The tack measurement point (Y) shall be defined by corner of the 90° template shown in the diagram. The sail shall be made so that the leading edge of the mast pocket is within 300mm of the measurement point. The template shall be placed so that the 450mm arm is aligned with the leading edge of mast pocket. The template shall be adjusted so that no part of the sail lies below the 250mm arm or its projection (fig. 3)

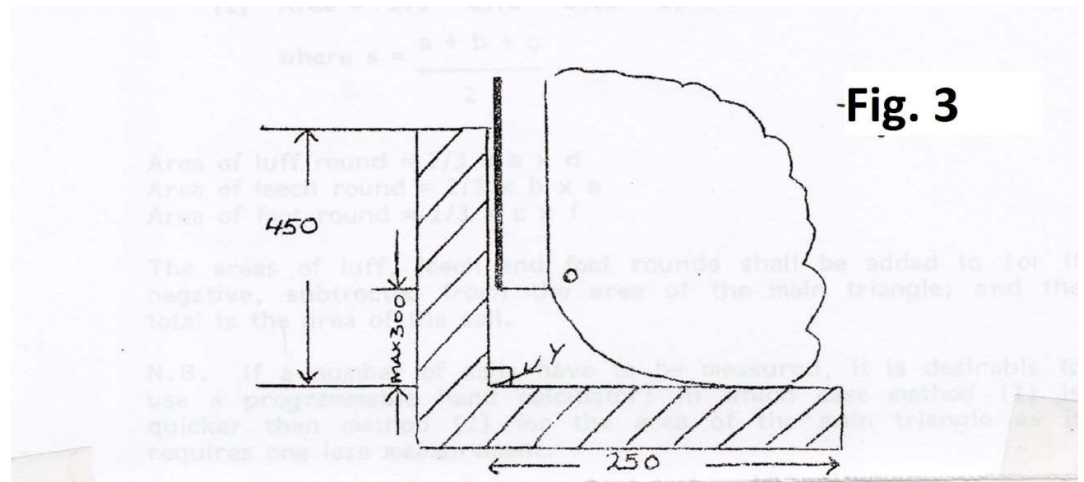

3.9.5 The clew measurement point (point Z) shall be the point at which the foot is or its extension intersects the leech or its extension

3.9.6 The head measurement point (point X), shall be the highest point on the forward edge of the mast pocket where the sail is 150 mm wide, measured perpendicular to the forward edge of the mast pocket. The sail shall be made so that the head can be found in this way.

3.9.7 Headboards are prohibited

3.9.8 A clew board is permitted

3.9.9 Battens shall be removed for measurement.

3.9.10 The sail area shall not be more than 7.5 m² measured in accordance with the following method

3.9.10.1 With sufficient tension applied between point X and Y, or as close as possible to those points, to remove all wrinkles perpendicular to the line between the points, the distance from X to Y shall be measured, to be the luff length, a.

3.9.10.2 With the tension maintained a straight chalk line shall be marked on the sail from point X to point Y. With the tension removed, measurement d shall be the maximum perpendicular offset from the chalk line to the forward edge of the luff pocket, projected if necessary through local variations in shape.

3.9.10.3 With sufficient tension applied between points Z and Y, or as close as possible to those points, to remove all wrinkles perpendicular between the points, the distance from Z and Y shall be measured, to be the foot length, c.

3.9.10.4 With the tension maintained a straight chalk line shall be marked on the sail from point Z to Y. With the tension removed, the area between the chalk line and the edge of the sail shall be measured by dividing it into trapeziums, triangles and segments and measuring the area of each. For the purpose of this instruction the area of a segment shall be taken as two third of the product of the chord of the round and the maximum perpendicular offset of the chord. This area shall be called the foot area.

3.9.10.5 With sufficient tension applied between points Z and X, or as close as possible to those points, to remove all wrinkles perpendicular to the line between the points, the distance from Z and X shall be measured, to be the leech length, b.

3.9.10.6 With tension maintained a straight chalk line shall be marked on the sail from point Z to X. The procedure described in rule 3.9.10.4 shall be used to measure the area between this chalk line and the edge of the sail, to be called the leech area.

3.9.10.7 The distance from point Z to the chalk line between points X and Y, measured perpendicular to the chalk line, shall be e.

3.9.10.8 The area of the sail shall be calculated by:

$$(a \times e)/2 + (a \times d) 2/3 + \text{foot area} + \text{leech area}$$

(point 3.9.10.4 and 3.9.10.6)

Or using;

$$S = (a \times e)/2 + (a \times d)2/3 + (b \times f)2/3 + (c \times g)2/3$$

3.9.11 Multiple attachment positions may be fitted at the tack and clew, any reefing system shall be fully extended for measurement purposes.

3.9.12 The sail shall carry the identification marks required by rule 2.6. Sail makers marks shall not exceed 300mm in diameter

3.9.13 Notwithstanding the above sail measurement rules, all sails complying with the current or previous edition of the Olympic Lechner A-390 Class Rules

may be used.

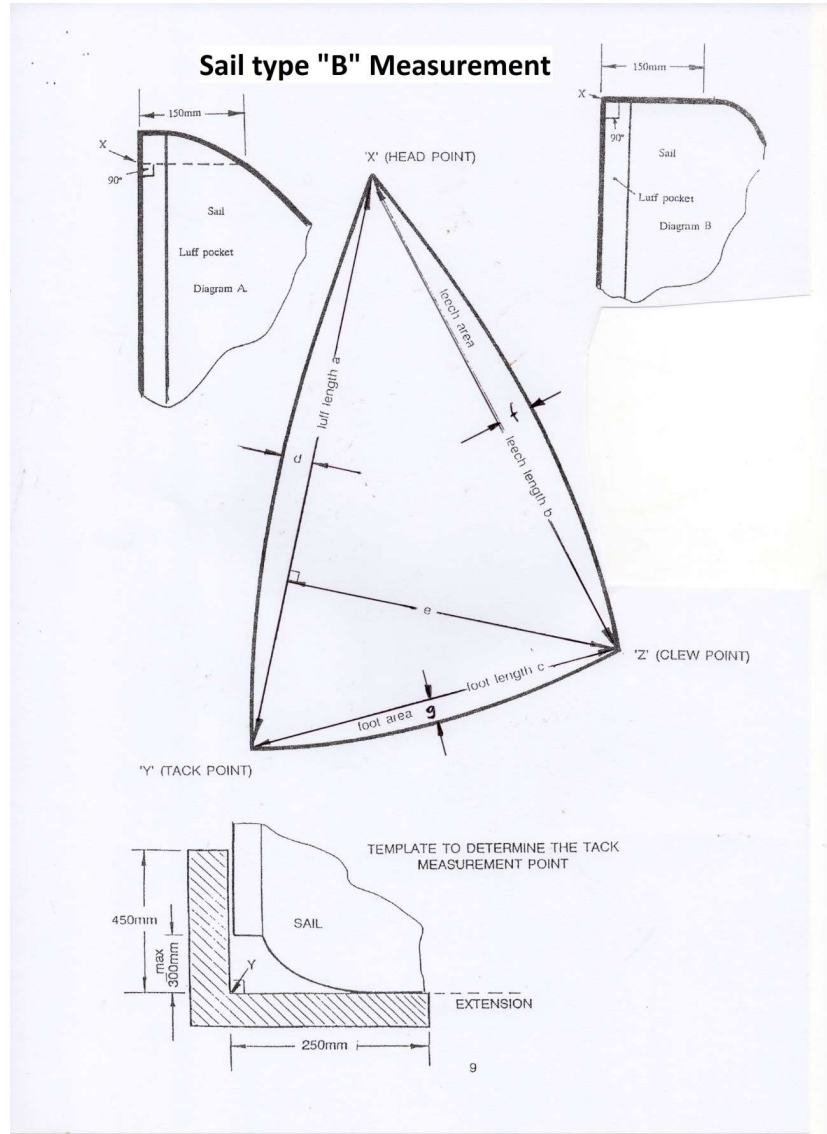

Sail type "B" class Lc

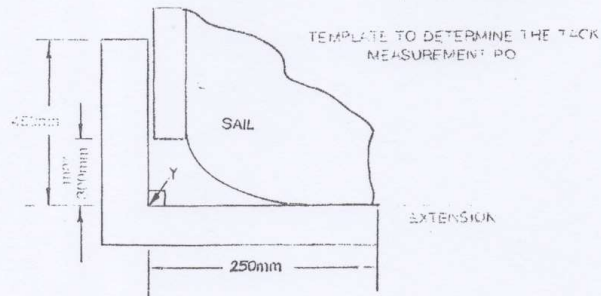
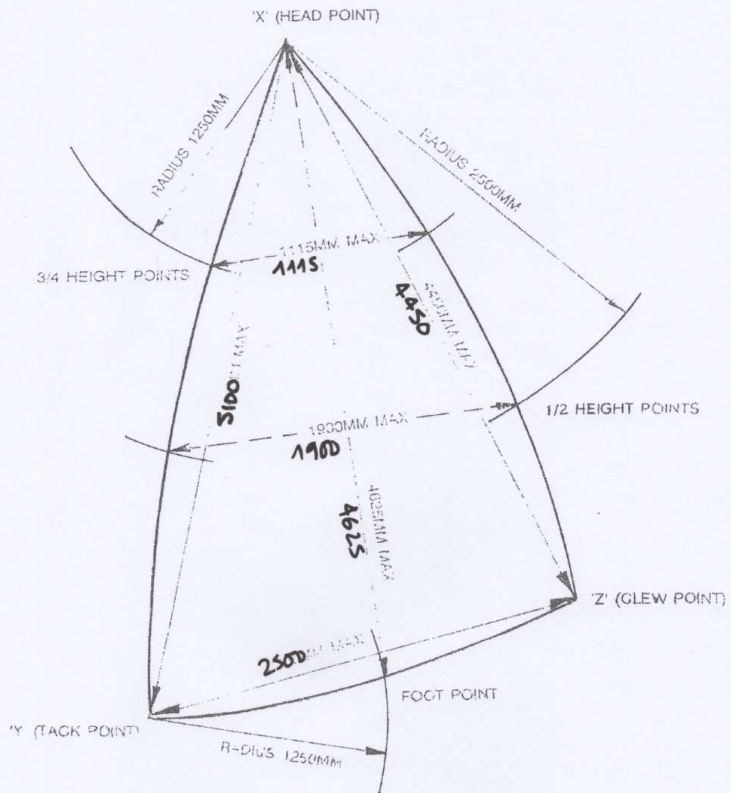

10

3.10 Type "C" Sail – Fully battened (optional design)

3.10.1 Size of the sails

Maximum sizes of sails authorized are 9.5 m² for men and 8.5 m² for women.

3.10.2 The number and length of battens is optional

3.10.3 Headboards are permitted

3.10.4 A clew board is permitted

3.10.5 The area of the sail shall be calculated by:

$$(a \times e)/2 + (a \times d) 2/3 + \text{foot area} + \text{leech area}$$

(point 3.9.10.4 and 3.9.10.6)

Or using;

$$S = (a \times e)/2 + (a \times d) 2/3 + (b \times f) 2/3 + (c \times g)2/3$$

4 CREW

The crew shall be one person

5 LIMITATION OF EQUIPMENT

5.1 During the regatta only one board, three sails and two centerboards may be used.

Only one sail and one centerboard shall be carried during a race.

The limited equipment shall not be altered in any way during the regatta without the permission of the Class Appointed Measurer. The Class Appointed Measurer may only permit substitution of limited equipment, if redress is granted. The only exceptions to this are theft and "force majeure". Where equipment is supplied by the Organizing Committee, if equipment is broken, it shall be replaced only after the approval of the Organizing Committee. Other equipment is interchangeable provided it complies with these rules.

5.2 A harness is permitted

5.3 Wind indicators and tell tales are permitted

5.4 A compass is permitted. The weight of the compass will not be included in the weight of the board.

5.5 A weight jacket is prohibited. The total weight of clothing and equipment worn or carried by a competitor shall not be capable of exceeding 9 kg when soaked with water and weighed as provided in Appendix H of IWA / WS racing rules.

6 RACING RULES

6.1 Racing will take place under ID2CA racing rules.

7 WEIGHT GROUPS : Sailors shall remain within weight throughout the regatta

7.1 It is recommended that there are two weight groups within the "Type A and B" class. The light weight group maximum should be below 75kg crew body weight and the heavy weight group minimum should be above 70 kg crew body weight.

7.2 For the "C" class the light weight group should be below 82 kg crew body weight and the heavy weight group minimum should be above 78 kg crew body weight.

7.3 Race committee can verify sailor's weight at any time prior to, during and immediately after last Event race.

7.3.1 Procedure to weight sailors is described in Paragraph 11 of Class Championship and Rules of Races.

APPENDIX A: Use of PENTOGRAPH and other methods of use of approved tools to measure Division II boards

See separate document.

ID2CA

Effective January 1st, 2024

Previous issue; ID2CA Class Equipment Rules 2017 V.01 (v.040517) 1st January 1989 (A and B) and May 4th 2017(C).